

2-3 轉造級滾珠螺桿

■ 2-3-1 轉造級滾珠螺桿介紹

轉造級滾珠螺桿是使用滾牙方式來生產螺桿，又稱軋製螺桿。相較於傳統艾克姆螺桿、方型螺桿之傳動方式，轉造級滾珠螺桿可提升運轉順暢度、降低軸向背隙及摩擦力等優點。相較於研磨級螺桿，轉造級螺桿更具有供貨迅速及價格實惠之優勢。

■ 2-3-2 TBI MOTION 轉造級滾珠螺桿特色

(1) 可達 C5 級精度

轉造級滾珠螺桿導程精度可達 C5 級，具有 C5、C7、C10 三種標準。

(2) 配用高精度螺帽

轉造級螺帽與研磨級螺帽的製程相同，皆為高精度之螺帽，具備高順暢性及耐久性。

(3) 可單獨出貨

轉造級螺帽及螺桿可以分開單獨出貨，在購買上較為便利。其螺帽出貨的標準為 P0 預壓，客戶可依需求自行換裝鋼珠調整預壓使用。

■ 2-3-3 轉造級滾珠螺桿公稱代號

轉造級螺桿代號

SC R 025 05 F C7 - 1000 + N3

① ② ③ ④ ⑤ ⑥ ⑦ ⑧

①	④	⑦
螺桿類型	導程	螺桿軸長度
SC: 標準型螺桿	單位 :mm	單位 :mm
SS: 專用型螺桿		
②	⑤	⑧
螺紋方向	製程代號	螺桿軸表面處理
R: 右	F: 轉造	□: 標準
L: 左		B1: 染黑
		N1: 鍍鉻
③	⑥	
螺桿軸外徑	導程精度等級	P: 磷酸鹽
單位 :mm	C5, C7, C10	N3: 鍍化鎳
		N4: 冷電鍍
		N5: 鍍黑鉻

滾珠螺桿產品系列

2-3 轉造級滾珠螺桿



圖 2.3.1 螺桿示意圖

表 2.3.1 轉造級庫存螺桿標準型尺寸規格對照表 Ø6~32

單位：mm

型號			導程精度等級	螺紋方向 R: 右 L: 左	牙口數	標準型 螺桿編碼	適用螺帽 型式	轉造螺桿 最長長度
外徑 d	導程 l	珠徑 Da						
6	1	0.8	C10, C7	R	1	SCR00601	K	1000
8	1	0.8	C10, C7	R	1	SCR00801	K	1000
	2	1.2	C10, C7	R	1	SCR00802	K	
	2.5	1.2	C10, C7	R	1	SCR0082.5	K, BSH	
10	2	1.2	C10, C7	R	1	SCR01002	K, BSH	3000
	4	2	C10, C7	R	1	SCR01004	K, BSH	
12	2	1.2	C10, C7	R	1	SCR01202	K	3000
	4	2.5	C10, C7	R	1	SCR01204	U, BSH	
	5	2.5	C10, C7	R	1	SSR01205	V, U, BSH, H, A	
	10	2.5	C10, C7	R	1	SCR01210-B	V	
14	2	1.2	C10, C7	R	1	SCR01402	K	3000
	4	2.5	C10, C7	R	1	SCR01404	K, BSH	3000
16	4	2.381	C10, C7	R	1	SCR01604(N)	V, I, U, BSH	3000
	5	3.175	C10, C7	R/L	1	SCR01605	V, NI, NU, BSH	
	10	3.175	C10, C7	R	1	SCR01610	V, NI, NU, BSH	
	16	2.778	C10, C7	R	4	SCR01616	Y	
20	32	2.778	C10, C7	R	8	SCR01632	Y	3000
	4	2.381	C10, C7	R	1	SCR02004(N)	V, I, U	
	5	3.175	C10, C7	R/L	1	SCR02005	V, NI, NU, BSH, H, A	
	20	3.175	C10, C7	R	4	SCR02020	V, Y, H, A	
25	40	3.175	C10, C7	R	8	SCR02040	Y	6000
	4	2.381	C10, C7	R	1	SCR02504(N)	I, U	
	5	3.175	C10, C7	R/L	1	SCR02505	V, NI, NU, BSH, H, A	
	10	4.762	C10, C7	R	1	SCR02510-A	NI, NU, BSH	
	25	3.969	C10, C7	R	4	SCR02525	Y	
32	50	3.969	C10, C7	R	8	SCR02550	Y	6000
	4	2.381	C10, C7	R	1	SCR03204(N)	V, I, U	
	5	3.175	C10, C7	R/L	1	SCR03205	V, NI, NU, M, H, A	
	10	6.35	C10, C7	R/L	1	SCR03210	V, NI, NU	
	32	4.762	C10, C7	R	4	SCR03232	Y	
	64	4.762	C10, C7	R	8	SCR03264	Y	

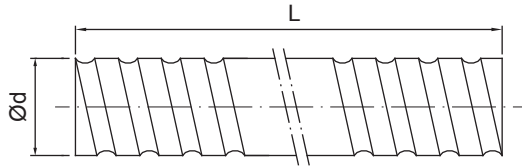
※ 以上為標準規範，若有 C5 及其他需求請洽 TBI MOTION 業務人員諮詢。

表 2.3.2 標準型尺寸規格對照表 Ø40~80

單位 : mm

外徑 d	型號		導程精度等級	螺紋方向	牙口數	標準型螺桿編碼	適用螺帽型式	轉造螺桿最長長度
	導程 l	珠徑 Da		R : 右 L : 左				
40	5	3.175	C10, C7	R/L	1	SCR04005	V, NI, NU, H, A	6000
	10	6.35	C10, C7	R/L	1	SCR04010	V, NI, NU	
	20	6.35	C10, C7	R	1	SCR04020	V	
	40	6.35	C10, C7	R	4	SCR04040	Y	
	80	6.35	C10, C7	R	8	SCR04080	Y	
50*	5	3.175	C10, C7	R	1	SCR05005	V, H, A	6000
	10	6.35	C10, C7	R/L	1	SCR05010	V, NI, NU	
	20	9.525	C10, C7	R	1	SCR05020	V	
	50	7.938	C10, C7	R	4	SCR05050	Y	
	100	7.938	C10, C7	R	8	SCR050100	Y	
63*	10	6.35	C10, C7	R	1	SCR06310	V, NI, NU	7000
	20	9.525	C10, C7	R	1	SCR06320	V, NU	
80*	10	6.35	C10, C7	R	1	SCR08010	V, NI, NU	7000
	20	9.525	C10, C7	R	1	SCR08020	V, NU	

表 2.3.3 H/A 型尺寸規格對照表 Ø16~50

單位 : mm

外徑 d	型號		導程精度等級	螺紋方向	牙口數	標準型螺桿編碼	適用螺帽型式	轉造螺桿最長長度
	導程 l	珠徑 Da		R : 右 L : 左				
12	10	2.5	C10, C7	R	2	SSR01210	H, A	3000
16	5	2.778	C10, C7	R	1	SSR01605	H, A	3000
	10	2.778	C10, C7	R	2	SSR01610	H, A	
	16	2.778	C10, C7	R	4	SSR01616	H, A	
	20	2.778	C10, C7	R	4	SSR01620	H, A	
20	10	3.175	C10, C7	R	2	SSR02010	H, A	3000
25	10	3.175	C10, C7	R	2	SSR02510	H, A	6000
	25	3.175	C10, C7	R	4	SSR02525	H, A, V	
32	10	3.969	C10, C7	R	1	SSR03210	H, A	6000
	20	3.969	C10, C7	R	2	SSR03220	H, A	
	32	3.969	C10, C7	R	4	SSR03232	H, A	
40	10	6.35	C10, C7	R	1	SSR04010	H, A	6000
	20	6.35	C10, C7	R	2	SSR04020	H, A	
	40	6.35	C10, C7	R	4	SSR04040	H, A	
50*	10	6.35	C10, C7	R	1	SSR05010	H, A	6000
	20	6.35	C10, C7	R	2	SSR05020	H, A	
	50	6.35	C10, C7	R	4	SSR05050	H, A	

※ 以上為標準規範，若有 C5 及其他需求請洽 TBI MOTION 業務人員諮詢。

※ 對於●型號有需求，請洽 TBI MOTION 業務人員。

滾珠螺桿產品系列

2-4 轉造級滾珠螺桿系列

轉造級螺帽代號

G SFU R 025 05 T4 D + N3

① ② ③ ④ ⑤ ⑥ ⑦ ⑧

①

製程代號

②

公稱型號

S: 單螺帽

D: 雙螺帽

F: 有法蘭

C: 無法蘭

NI :NI 型螺帽

NU :NU 型螺帽

H :H 型螺帽

A :A 型螺帽

NH:NH 型螺帽 (滑台專用)

Y :Y 型螺帽

V :V 型螺帽

U :U 型螺帽

M :M 型螺帽

K :K 型螺帽

③

螺紋方向

R: 右

L: 左

④

螺桿軸外徑

單位 :mm

⑤

導程

單位 :mm

⑥

珠卷數 (卷數 · 列數)

卷數 :T:1

A:1.5 (or 1.7/1.8)

B:2.5/2.8

C:3.5

D:4.8

E:5.8

例 : (2.5 × 2 = B2)

⑦

法蘭型式

N: 無切邊

S: 單切邊

D: 雙切邊

⑧

螺帽表面處理

S: 標準

B1: 染黑

N1: 鍍鎳

P: 磷酸鹽

N3: 鍍化鎳

N4: 冷電鍍

N5: 鍍黑鉻

■ 2-3-4 轉造級滾珠螺桿預壓規範

轉造級滾珠螺桿標準預壓為 P0，若需要 P1 預壓，請連繫 **TBI MOTION** 業務人員。

表 2.3.4 轉造級螺桿精度規範表

單位 : μm

精度等級	C5 (DIN)	C7	C10
e300	23	50	210

■ 2-4-1 TBI MOTION 轉造級螺帽型式

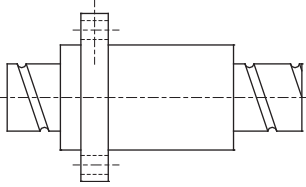
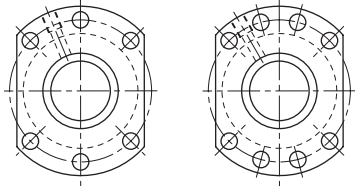
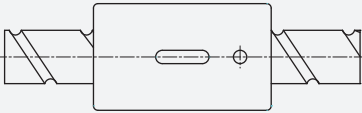
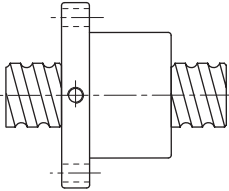
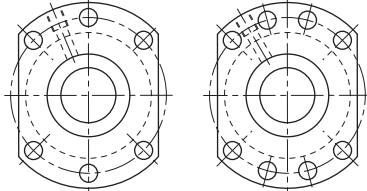
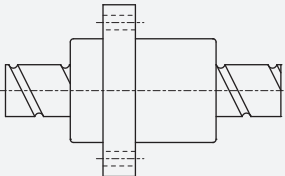
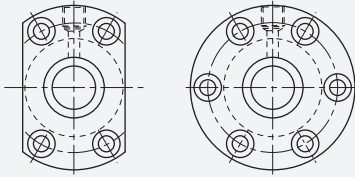
	轉造級螺帽型式	法蘭型式
NH/H/A (滑台專用型 / 高速強化防塵型)	<p>SFNH/SFH/SFA(DIN)</p>  <p>C70、71</p>	 <p>$d \leq 32$ $d \geq 40$</p>
CNH (滑台專用型)	<p>SCNH</p>  <p>C72</p>	無法蘭
NU/U (強化防塵型)	<p>SFNU/SFU(DIN)</p>  <p>C73</p>	 <p>$d \leq 32$ $d \geq 40$</p>
NI/I (強化防塵型)	<p>SFNI/SFI</p>  <p>C74</p>	

C

滾珠螺桿

滾珠螺桿產品系列

2-4 轉造級滾珠螺桿系列

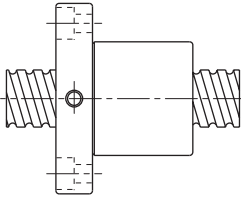
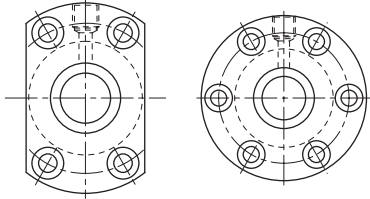
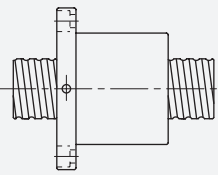
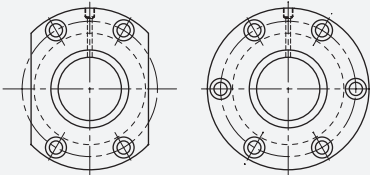
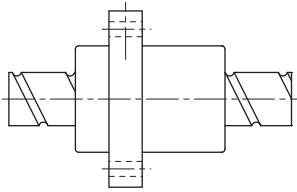
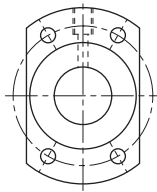
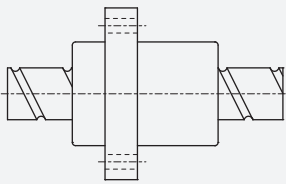
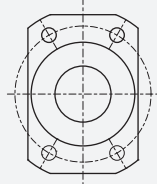
轉造級螺帽型式		法蘭型式
M (銑床專用)	<p>SFM</p>  <p>C74</p>	
V (重負荷外循環型)	<p>SFV</p>  <p>C75</p>	
Y (高Dm-N值)	<p>SFY</p>  <p>C76</p>	
XSY (微小型)	<p>XSY</p>  <p>C77</p>	

C

滾珠螺桿

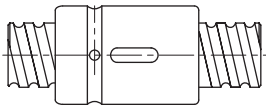
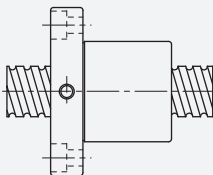
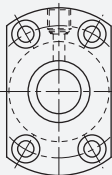
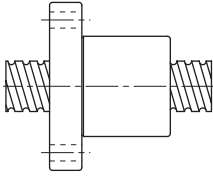
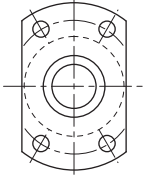
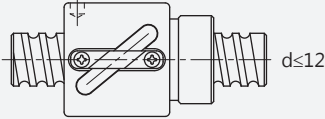
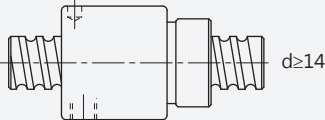
	轉造級螺帽型式	法蘭型式
CNI/I (標準型)	<p>SCNI/SCI</p>  <p>C78</p>	無法蘭
K (微型)	<p>SFK</p>  <p>C79</p>	 <p>(SFK 01004) (SFK 02002) (SFK 02502)</p>
	<p>SFK</p>  <p>C79</p>	
BSH	<p>BSH</p>  <p>$d \leq 12$</p>  <p>$d \geq 14$</p> <p>C80</p>	無法蘭

※ 如有不同的設計尺寸，請洽詢 TBI MOTION 業務人員。

滾珠螺桿產品系列

2-4 轉造級滾珠螺桿系列

SFNH/SFH (DIN 69051 FORM B) 轉造級系列規格尺寸表

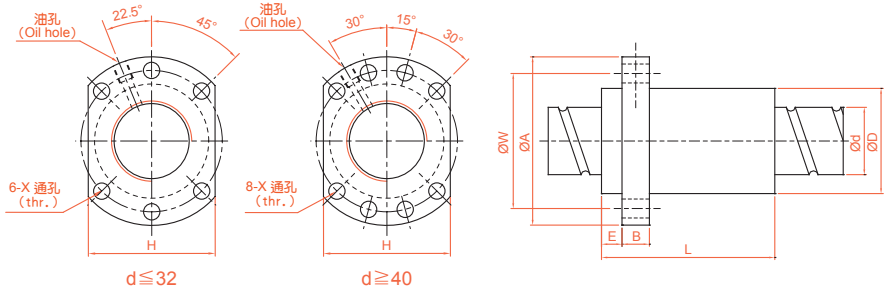

單位: mm

型號	軸徑 d	導程 l	珠徑 Da	Dimension											動額定 負荷 Ca(kgf)	靜額定 負荷 Coa(kgf)	剛性 kgf/μm
				D	A	E	B	L	W	H	X	Q	n				
SFH01205-2.8*	12	5	2.5	24	40	5	10	30	32	30	4.5	-	2.8x1	661	1316	19	
SFH01210-2.8*		10	2.5	24	40	5	10	45	32	30	4.5	-	2.8x1	642	1287	19	
SFH01605-3.8*	15	5	2.778	28	48	5	10	37	38	40	5.5	M6	3.8x1	1112	2507	30	
SFH01610-2.8*		10	2.778	28	48	5	10	45	38	40	5.5	M6	2.8x1	839	1821	23	
SFH01616-1.8*	15	16	2.778	28	48	5	10	45	38	40	5.5	M6	1.8x1	552	1137	14	
SFH01616-2.8*		16	2.778	28	48	5	10	61	38	40	5.5	M6	2.8x1	808	1769	22	
SFH01620-1.8*	20	2.778	28	48	7	10	58	38	40	5.5	M6	1.8x1	554	1170	14		
SFH02005-3.8*	20	5	3.175	36	58	7	10	37	47	44	6.6	M6	3.8x1	1484	3681	37	
SFH02010-3.8*		10	3.175	36	58	7	10	55	47	44	6.6	M6	3.8x1	1516	3833	40	
SFH02020-1.8*	20	20	3.175	36	58	7	10	54	47	44	6.6	M6	1.8x1	764	1758	19	
SFH02020-2.8*		20	3.175	36	58	7	10	74	47	44	6.6	M6	2.8x1	1118	2734	29	
SFH02505-3.8*	25	5	3.175	40	62	7	10	37	51	48	6.6	M6	3.8x1	1650	4658	43	
SFH02510-3.8*		10	3.175	40	62	7	12	55	51	48	6.6	M6	3.8x1	1638	4633	45	
SFH02525-1.8*	25	25	3.175	40	62	7	12	64	51	48	6.6	M6	1.8x1	843	2199	22	
SFH02525-2.8*		25	3.175	40	62	7	12	89	51	48	6.6	M6	2.8x1	1232	3421	34	
SFH03205-3.8	32	5	3.175	50	80	9	12	37	65	62	9	M6	3.8x1	1839	6026	51	
SFH03210-3.8	31	10	3.969	50	80	9	12	57	65	62	9	M6	3.8x1	2460	7255	55	
SFH03220-2.8		20	3.969	50	80	9	12	76	65	62	9	M6	2.8x1	1907	5482	43	
SFH03232-1.8	31	32	3.969	50	80	9	12	80	65	62	9	M6	1.8x1	1257	3426	27	
SFH03232-2.8		32	3.969	50	80	9	12	112	65	62	9	M6	2.8x1	1838	5329	42	
SFH04005-3.8	40	5	3.175	63	93	9	15	42	78	70	9	M8	3.8x1	2018	7589	60	
SFH04010-3.8	38	10	6.35	63	93	9	14	60	78	70	9	M8	3.8x1	5035	13943	67	
SFH04020-2.8		20	6.35	63	93	9	14	80	78	70	9	M8	2.8x1	3959	10715	54	
SFH04040-1.8	38	40	6.35	63	93	9	14	98	78	70	9	M8	1.8x1	2585	6648	34	
SFH04040-2.8		40	6.35	63	93	9	14	138	78	70	9	M8	2.8x1	3780	10341	52	
SFH05005-3.8*	50	5	3.175	75	110	10.5	15	42	93	85	11	M8	3.8x1	2207	9542	68	
SFH05010-3.8*	48	10	6.35	75	110	10.5	18	60	93	85	11	M8	3.8x1	5638	17852	79	
SFH05020-3.8*		20	6.35	75	110	10.5	18	100	93	85	11	M8	3.8x1	5749	18485	87	
SFH05050-1.8*	48	50	6.35	75	110	10.5	18	120	93	85	11	M8	1.8x1	2946	8749	42	
SFH05050-2.8*		50	6.35	75	110	10.5	18	170	93	85	11	M8	2.8x1	4308	13610	65	

※ 有標註★記號者可製作 SFNH 滑台專用規範。
 ※ 對於●型號有需求，請洽 TBI MOTION 業務人員。

SFA 轉造級系列規格尺寸表

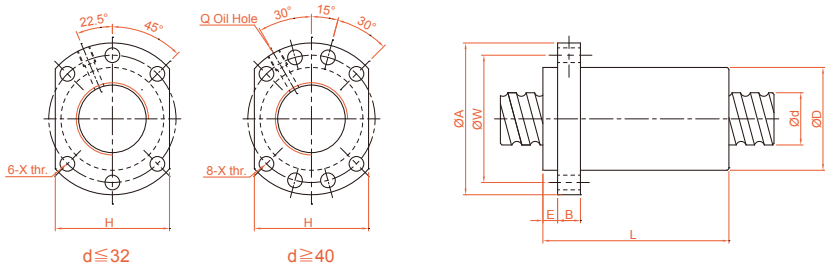

單位：mm

型號	軸徑 d	導程 l	珠徑 Da	螺帽尺寸										滾珠螺帽額定負荷		剛性 kgf/ µm
				D	A	E	B	L	W	H	X	Q	n	Ca (kgf)	Coa (kgf)	
SFA1205-2.8*	12	5	2.5	24	40	5	10	30	32	30	4.5	-	2.8×1	661	1316	19
SFA1210-2.8*		10	2.5	24	40	5	10	42	32	30	4.5	-	2.8×1	642	1287	19
SFA1605-3.8*	15	5	2.778	28	48	5	10	31	38	40	5.5	M6	3.8×1	1112	2507	30
SFA1610-2.8*		10	2.778	28	48	5	10	42	38	40	5.5	M6	2.8×1	839	1821	23
SFA1616-1.8*		16	2.778	28	48	5	10	43	38	40	5.5	M6	1.8×1	552	1137	14
SFA1616-2.8*		16	2.778	28	48	5	10	59	38	40	5.5	M6	2.8×1	808	1769	22
SFA1620-1.8*	20	20	2.778	28	48	5	10	50	38	40	5.5	M6	1.8×1	554	1170	14
SFA2005-3.8*		5	3.175	36	58	7	10	33	47	44	6.6	M6	3.8×1	1484	3681	37
SFA2010-3.8*		10	3.175	36	58	7	10	52	47	44	6.6	M6	3.8×1	1516	3833	40
SFA2020-1.8*		20	3.175	36	58	7	10	52	47	44	6.6	M6	1.8×1	764	1758	19
SFA2020-2.8*	25	20	3.175	36	58	7	10	72	47	44	6.6	M6	2.8×1	1118	2734	29
SFA2505-3.8*		5	3.175	40	62	7	10	33	51	48	6.6	M6	3.8×1	1650	4658	43
SFA2510-3.8*		10	3.175	40	62	7	12	52	51	48	6.6	M6	3.8×1	1638	4633	45
SFA2525-1.8*		25	3.175	40	62	7	12	60	51	48	6.6	M6	1.8×1	843	2199	22
SFA2525-2.8*	32	25	3.175	40	62	7	12	85	51	48	6.6	M6	2.8×1	1232	3421	34
SFA3205-3.8		5	3.175	50	80	9	12	35	65	62	9	M6	3.8×1	1839	6026	51
SFA3210-3.8		10	3.969	50	80	9	12	53	65	62	9	M6	3.8×1	2460	7255	55
SFA3220-2.8		20	3.969	50	80	9	12	72	65	62	9	M6	2.8×1	1907	5482	43
SFA3232-1.8	31	32	3.969	50	80	9	12	78	65	62	9	M6	1.8×1	1257	3426	27
SFA3232-2.8		32	3.969	50	80	9	12	110	65	62	9	M6	2.8×1	1838	5329	42
SFA4005-3.8	40	5	3.175	63	93	9	14	39	78	70	9	M8	3.8×1	2018	7589	60
SFA4010-3.8		10	6.35	63	93	9	14	57	78	70	9	M8	3.8×1	5035	13943	67
SFA4020-2.8		20	6.35	63	93	9	14	78	78	70	9	M8	2.8×1	3959	10715	54
SFA4040-1.8		40	6.35	63	93	9	14	96	78	70	9	M8	1.8×1	2585	6648	34
SFA4040-2.8	50	40	6.35	63	93	9	14	136	78	70	9	M8	2.8×1	3780	10341	52
SFA5005-3.8*		5	3.175	75	110	10.5	15	42	93	85	11	M8	3.8×1	2207	9542	68
SFA5010-3.8*		10	6.35	75	110	10.5	18	57	93	85	11	M8	3.8×1	5638	17852	79
SFA5020-3.8*		20	6.35	75	110	10.5	18	98	93	85	11	M8	3.8×1	5749	18485	87
SFA5050-1.8*	48	50	6.35	75	110	10.5	18	117	93	85	11	M8	1.8×1	2946	8749	42
SFA5050-2.8*		50	6.35	75	110	10.5	18	167	93	85	11	M8	2.8×1	4308	13610	65

※ 有標註★記號者可製作 SFNH 滑台專用規範。
 ※ 對於●型號有需求，請洽 TBI MOTION 業務人員。

滾珠螺桿產品系列

2-4 轉造級滾珠螺桿系列

SCNH 轉造級系列規格尺寸表

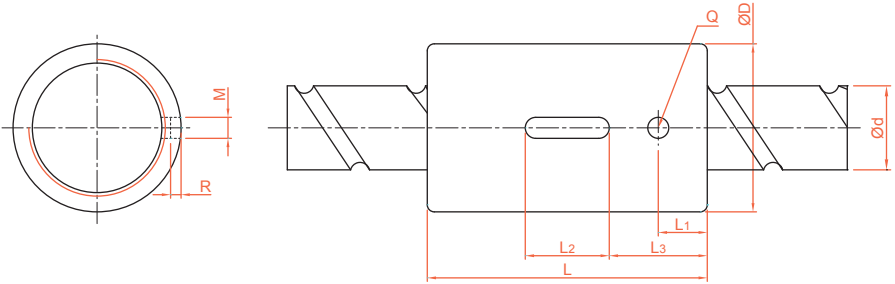

單位 : mm

型號	軸徑 d	導程 l	珠徑 D_a	螺帽尺寸									動額定 負荷 C_a (kgf)	靜額定 負荷 C_oa (kgf)	剛性 $kgf/\mu m$
				D	L	L_1	L_2	L_3	M	R	Q	n			
SCNH01205-4.8	12	5	2.5	24	40	7	12	14	3	1.5	3	4.8x1	1051	2255	34
SCNH01210-2.8		10	2.5	24	45	8	15	15	3	1.5	3	2.8x1	642	1287	19
XCNH01210-1.8		10	2.5	24	40	10.5	12	14	3	1.5	3	1.8x1	439	827	33
SCNH01605-5.8	15	5	2.778	28	45	7	20	12.5	5	3	3	5.8x1	1599	3827	49
SCNH01610-2.8		10	2.778	28	45	7	20	12.5	5	3	3	2.8x1	839	1821	23
SCNH01616-1.8		16	2.778	28	45	7	20	12.5	5	3	3	1.8x1	552	1137	18
SCNH01620-1.8		20	2.778	28	58	10	20	19	5	3	3	1.8x1	554	1170	14
SCNH02005-5.8	20	5	3.175	36	47	8	20	13.5	5	3	3	5.8x1	2134	5619	60
SCNH02010-3.8		10	3.175	36	55	8	20	17.5	5	3	3	3.8x1	1516	3833	40
SCNH02020-1.8		20	3.175	36	55	8	20	17.5	5	3	3	1.8x1	764	1758	19

SFNU/SFU (DIN 69051 FORM B) 轉造級系列規格尺寸表

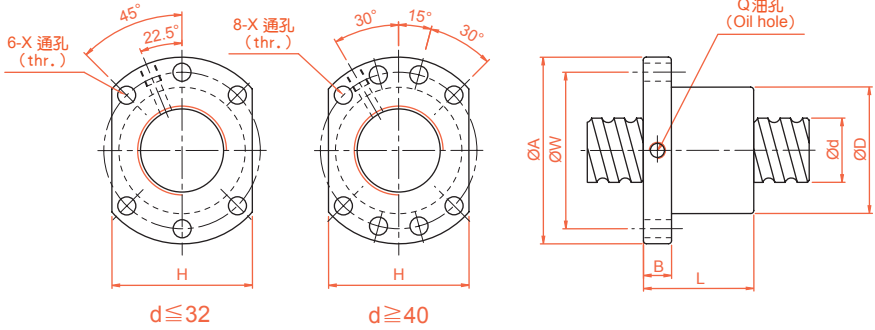

單位：mm

型號	軸徑 d	導程 l	珠徑 Da	螺帽尺寸									動額定 負荷 Ca(kgf)	靜額定 負荷 Coa(kgf)	剛性 kg/ μ m
				D	A	B	L	W	H	X	Q	n			
SFNU01605-4*	16	5	3.175	28	48	10	45	38	40	5.5	M6	1x4	1380	3052	32
SFNU01610-3		10	3.175	28	48	10	57	38	40	5.5	M6	1x3	1103	2401	26
SFNU02005-4*	20	5	3.175	36	58	10	51	47	44	6.6	M6	1x4	1551	3875	39
SFNU02505-4*		5	3.175	40	62	10	51	51	48	6.6	M6	1x4	1724	4904	45
SFNU02510-4	25	10	4.762	40	62	12	80	51	48	6.6	M6	1x4	2954	7295	50
SFNU03205-4*		5	3.175	50	80	12	52	65	62	9	M6	1x4	1922	6343	54
SFNU03210-4*	32	10	6.35	50	80	12	85	65	62	9	M6	1x4	4805	12208	61
SFNU04005-4*		5	3.175	63	93	14	55	78	70	9	M8	1x4	2110	7988	63
SFNU04010-4*	40	10	6.35	63	93	14	88	78	70	9	M8	1x4	5399	15500	73
SFNU05010-4**		50	10	6.35	75	110	16	88	93	85	11	M8	1x4	6004	19614
SFNU06310-4*	63	10	6.35	90	125	18	93	108	95	11	M8	1x4	6719	25358	99
SFNU08010-4*		80	10	6.35	105	145	20	93	125	110	13.5	M8	1x4	7346	31953
SFU01204-4	12	4	2.5	24	40	10	40	32	30	4.5		1x4	902	1884	26
SFU01604-4		16	4	2.381	28	48	10	40	38	40	5.5	M6	1x4	973	2406
SFU02004-4	20	4	2.381	36	58	10	42	47	44	6.6	M6	1x4	1066	2987	38
SFU02504-4		4	2.381	40	62	10	42	51	48	6.6	M6	1x4	1180	3795	43
SFU02506-4	25	6	3.969	40	62	10	54	51	48	6.6	M6	1x4	2318	6057	47
SFU02508-4		8	4.762	40	62	10	63	51	48	6.6	M6	1x4	2963	7313	49
SFU03204-4	32	4	2.381	50	80	12	44	65	62	9	M6	1x4	1296	4838	51
SFU03206-4		6	3.969	50	80	12	57	65	62	9	M6	1x4	2632	7979	57
SFU03208-4		8	4.762	50	80	12	65	65	62	9	M6	1x4	3387	9622	60
SFU04006-4		6	3.969	63	93	14	60	78	70	9	M6	1x4	2873	9913	66
SFU04008-4	40	8	4.762	63	93	14	67	78	70	9	M6	1x4	3712	11947	70
SFU06320-4*		63	20	9.525	95	135	20	149	115	100	13.5	M8	1x4	11444	36653
SFU08020-4*	80	20	9.525	125	165	25	154	145	130	13.5	M8	1x4	12911	47747	138
SFU10020-4*		100	20	9.525	150	202	30	180	170	155	17.5	M8	1x4	14303	60698

※ 有標註☆記號者可製作左螺紋。

※ 對於●型號有需求，請洽 TBI MOTION 業務人員。 ※ SFU01204-4 螺帽標準品無附刮刷器。

滾珠螺桿產品系列

2-4 轉造級滾珠螺桿系列

SFNI/SFI 轉造級系列規格尺寸表

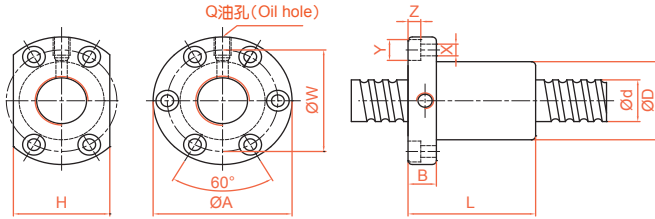

單位: mm

型號	軸徑 d	導程 l	珠徑 Da	螺帽尺寸											動額定負荷 Ca(kgf)	靜額定負荷 Coa(kgf)	剛性 kgf/μm
				D	A	B	L	W	H	X	Y	Z	Q	n			
SFNI01605-4*	16	5	3.175	30	49	10	45	39	34	4.5	8	4.5	M6	1x4	1380	3052	33
SFNI01610-3		10	3.175	34	58	10	57	45	34	5.5	9.5	5.5	M6	1x3	1103	2401	27
SFNI02005-4*	20	5	3.175	34	57	11	51	45	40	5.5	9.5	5.5	M6	1x4	1551	3875	39
SFNI02505-4*		5	3.175	40	63	11	51	51	46	5.5	9.5	5.5	M8	1x4	1724	4904	45
SFNI02510-4	25	10	4.762	46	72	12	80	58	52	6.5	11	6.5	M6	1x4	2954	7295	51
SFNI03205-4*		5	3.175	46	72	12	52	58	52	6.5	11	6.5	M8	1x4	1922	6343	52
SFNI03210-4*	32	10	6.35	54	88	15	85	70	62	9	14	8.5	M8	1x4	4805	12208	62
SFNI04005-4*		5	3.175	56	90	15	55	72	64	9	14	8.5	M8	1x4	2110	7988	59
SFNI04010-4*	40	10	6.35	62	104	18	88	82	70	11	17.5	11	M8	1x4	5399	15500	72
SFNI05010-4*		50	6.35	72	114	18	88	92	82	11	17.5	11	M8	1x4	6004	19614	83
SFNI06310-4*	63	10	6.35	85	131	22	93	107	95	14	20	13	M8	1x4	6719	25358	95
SFNI08010-4*		80	10	6.35	105	150	22	93	127	115	14	20	13	M8	1x4	7346	31953
SFI01604-4	16	4	2.381	30	49	10	45	39	34	4.5	8	4.5	M6	1x4	973	2406	32
SFI02004-4		4	2.381	34	57	11	46	45	40	5.5	9.5	5.5	M6	1x4	1066	2987	37
SFI0205T-4	20	5.08	3.175	34	57	11	51	45	40	5.5	9.5	5.5	M6	1x4	1550	3875	39
SFI02504-4		4	2.381	40	63	11	46	51	46	5.5	9.5	5.5	M6	1x4	1180	3795	43
SFI0255T-4	25	5.08	3.175	40	63	11	51	46	5.5	9.5	5.5	M8	1x4	1724	4903	45	
SFI03204-4		32	4	2.381	46	72	12	47	58	52	6.5	11	6.5	M6	1x4	1296	4838

SFM 轉造級系列規格尺寸表 (銑床專用)

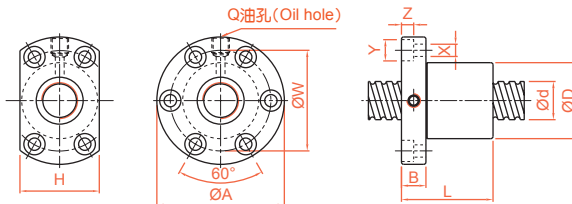

單位: mm

型號	軸徑 d	導程 l	珠徑 Da	螺帽尺寸											動額定負荷 Ca(kgf)	靜額定負荷 Coa(kgf)	剛性 kgf/μm
				D	A	B	L	W	H	X	Y	Z	Q	n			
SFM03205-4*	32	5	3.175	48	74	12	52	60	60	6.5	11	6.5	M8	1x4	1922	6343	53
SFM0325T-4*		5.08	3.175	48	74	12	53	60	60	6.5	11	6.5	M8	1x4	1922	6343	53

- * 有標註☆記號者可製作左螺紋。
- ** 對於●型號有需求，請洽 TBI MOTION 業務人員。

SFV 轉造級系列規格尺寸表

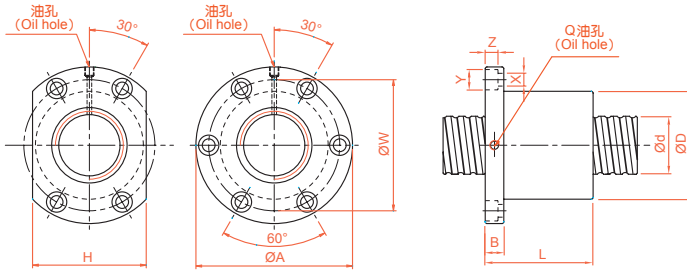

單位：mm

型號	軸徑 d	導程 l	珠徑 Da	螺帽尺寸											動額定 負荷 Ca(kgf)	靜額定 負荷 Coa(kgf)	剛性 kgf/ μm
				D	A	B	L	W	H	X	Y	Z	Q	n			
SFV01205-2.8	12	5	2.5	30	50	10	42	40	32	4.5	8	4.5	M6	2.8x1	661	1316	19
SFV01210-2.7		10	2.5	30	50	10	53	40	32	4.5	8	4.5	M6	2.7x1	623	1241	18
SFV01604-3.8	16	4	2.381	34	57	11	45	45	34	5.5	9.5	5.5	M6	3.8x1	931	2285	31
SFV01605-4.8		5	3.175	40	63	11	58	51	42	5.5	9.5	5.5	M6	4.8x1	1614	3662	40
SFV01610-2.7	10	3.175	40	63	11	56	51	42	5.5	9.5	5.5	M6	2.7x1	1008	2161	24	
SFV02004-4.8	20	4	2.381	40	60	10	50	50	40	4.5	8	4	M6	4.8x1	1247	3584	45
SFV02005-4.8		5	3.175	44	67	11	57	55	52	5.5	9.5	5.5	M6	4.8x1	1814	4650	47
SFV02020-1.8	20	3.175	46	74	13	70	59	46	6.6	11	6.5	M6	1.8x1	764	1758	19	
SFV02505-4.8	25	5	3.175	50	73	11	55	61	52	5.5	9.5	5.5	M8	4.8x1	2017	5884	56
SFV02525-1.8		25	3.175	50	73	13	83	61	52	5.5	9.5	5.5	M8	1.8x1	843	2199	22
SFV03204-4.8	32	4	2.381	54	81	12	50	67	64	6.6	11	6.5	M6	4.8x1	1517	5806	62
SFV03205-4.8		5	3.175	58	85	12	56	71	64	6.6	11	6.5	M8	4.8x1	2249	7612	66
SFV03210-4.8	10	6.35	74	108	15	96	90	82	9	14	9	M8	4.8x1	5620	14649	76	
SFV04005-4.8	40	5	3.175	67	101	15	59	83	72	9	14	8.5	M8	4.8x1	2468	9586	76
SFV04010-4.8		10	6.35	82	124	18	100	102	94	11	17.5	11	M8	4.8x1	6316	18600	90
SFV04020-2.7	20	6.35	82	124	18	100	102	90	11	17.5	11	M8	2.7x1	3935	10893	56	
SFV05005-4.8*	50	5	3.175	80	114	15	60	96	82	9	14	8.5	M8	4.8x1	2698	12053	87
SFV05010-4.8*		10	6.35	93	135	16	93	113	98	11	17.5	11	M8	4.8x1	7023	23537	106
SFV05020-2.7*	20	9.525	105	152	28	121	128	110	14	20	13	M8	2.7x1	7336	19700	68	
SFV06310-4.8*	63	10	6.35	108	154	22	105	130	110	14	20	13	M8	4.8x1	7860	30430	126
SFV06320-2.7*		20	9.525	122	180	28	120	150	130	18	26	17.5	M8	2.7x1	8162	24741	80
SFV08010-4.8*	80	10	6.35	130	176	22	105	152	132	14	20	13	M8	4.8x1	8593	38344	145
SFV08020-4.8*		20	9.525	143	204	28	180	172	148	18	26	18	M8	4.8x1	15103	57296	168
SFV08020-7.6*	20	9.525	143	204	28	240	172	148	18	26	18	M8	3.8x2	22423	90719	260	

※ 對於●型號有需求，請洽 TBI MOTION 業務人員。

C

滾珠螺桿

滾珠螺桿產品系列

2-4 轉造級滾珠螺桿系列

SFY 轉造級系列規格尺寸表

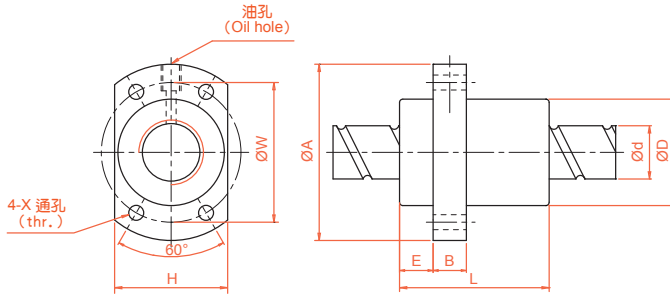

單位：mm

一倍導程 公稱型號	軸徑 d	導程 l	珠徑 Da	螺帽尺寸										動額定 負荷 Ca(kgf)	靜額定 負荷 Coa(kgf)	剛性 kgf/ µm
				D	A	E	B	L	W	H	X	Q	n			
SFY01616-3.6	16	16	2.778	32	53	10.1	10	45	42	34	4.5	M6	1.8x2	1073	2551	31
SFY02020-3.6	20	20	3.175	39	62	13	10	52	50	41	5.5	M6	1.8x2	1387	3515	37
SFY02525-3.6	25	25	3.969	47	74	15	12	64	60	49	6.6	M6	1.8x2	2074	5494	45
SFY03232-3.6	32	32	4.762	58	92	17	12	78	74	60	9	M6	1.8x2	3021	8690	58
SFY04040-3.6	40	40	6.35	73	114	19.5	15	99	93	75	11	M6	1.8x2	4831	14062	70
SFY05050-3.6*	50	50	7.938	90	135	21.5	20	117	112	92	14	M6	1.8x2	7220	21974	86
二倍導程 公稱型號	軸徑 d	導程 l	珠徑 Da	螺帽尺寸										動額定 負荷 Ca(kgf)	靜額定 負荷 Coa(kgf)	剛性 kgf/ µm
				D	A	E	B	L	W	H	X	Q	n			
SFY01632-1.6	16	32	2.778	32	53	10.1	10	42.5	42	34	4.5	M6	0.8x2	493	1116	11
SFY02040-1.6	20	40	3.175	39	62	13	10	48	50	41	5.5	M6	0.8x2	653	1597	15
SFY02550-1.6	25	50	3.969	47	74	15	12	58	60	49	6.6	M6	0.8x2	976	2495	19
SFY03264-1.6	32	64	4.762	58	92	17	12	71	74	60	9	M6	0.8x2	1374	3571	22
SFY04080-1.6	40	80	6.35	73	114	19.5	15	90	93	75	11	M6	0.8x2	2273	6387	29
SFY050100-1.6*	50	100	7.938	90	135	21.5	20	111	112	92	14	M6	0.8x2	3398	9980	35

※ 對於●型號有需求，請洽 TBI MOTION 業務人員。

XSY 轉造級系列規格尺寸表

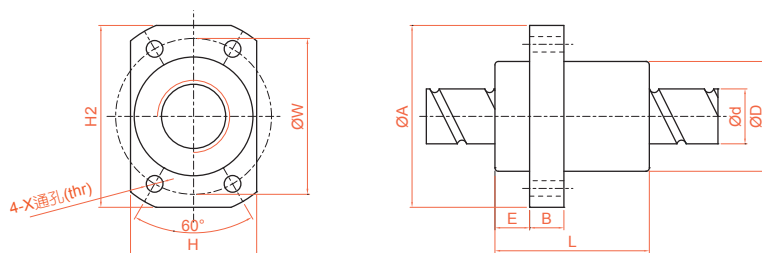

單位 : mm

型號	軸徑 d	導程 l	珠徑 Da	螺帽尺寸											動額定 負荷 Ca(kgf)	靜額定 負荷 Coa(kgf)	剛性 kgf/μm
				D	A	E	B	L	W	H	H2	X	n				
XSYR01220A2D-00	12	20	2.5	24	41	3.8	5	50	32	24	36	4.5	1.8x2	777	1718	13	

C

滾珠螺桿

滾珠螺桿產品系列

2-4 轉造級滾珠螺桿系列

SCNI/SCI 轉造級系列規格尺寸表

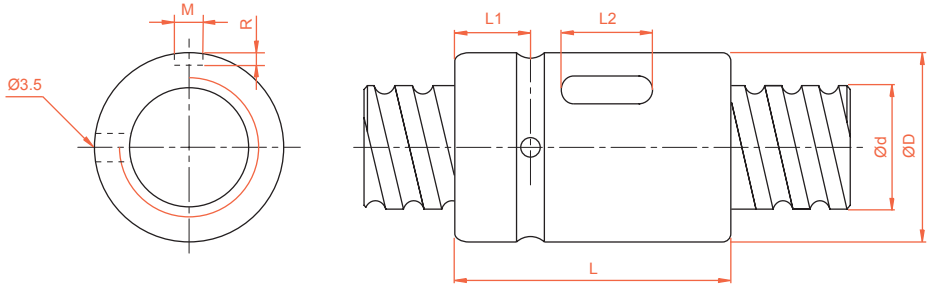

單位：mm

型號	軸徑 d	導程 l	珠徑 Da	螺帽尺寸							動額定 負荷 Ca(kgf)	靜額定 負荷 Coa(kgf)	剛性 kgf/μm
				D	L	L1	L2	M	R	n			
SCNI 01605-4	16	5	3.175	30	45	9	20	5	3	1x4	1380	3052	33
SCNI 02005-4	20	5	3.175	34	45	9	20	5	3	1x4	1551	3875	39
SCNI 02505-4	25	5	3.175	40	45	9	20	5	3	1x4	1724	4904	45
SCNI 02510-4		10	4.762	46	85	13	30	5	3	1x4	2954	7295	51
SCNI 03205-4	32	5	3.175	46	45	9	20	5	3	1x4	1922	6343	52
SCNI 03210-4		10	6.35	54	85	13	30	5	3	1x4	4805	12208	62
SCNI 04005-4	40	5	3.175	56	45	9	20	5	3	1x4	2110	7988	59
SCNI 04010-4		10	6.35	62	85	13	30	5	3	1x4	5399	15500	72
SCNI 05010-4*	50	10	6.35	72	85	13	30	5	3	1x4	6004	19614	83
SCNI 06310-4*	63	10	6.35	85	85	13	30	6	3.5	1x4	6719	25358	95
SCNI 08010-4*	80	10	6.35	105	85	13	30	8	4.5	1x4	7346	31953	109
SCI 01604-4	16	4	2.381	30	40	9	15	3	1.5	1x4	973	2406	32
SCI 02004-4	20	4	2.381	34	40	9	15	3	1.5	1x4	1066	2987	37
SCI 02504-4	25	4	2.381	40	40	9	15	3	1.5	1x4	1180	3795	43
SCI 03204-4	32	4	2.381	46	40	9	15	3	1.5	1x4	1296	4838	49

※ 對於●型號有需求，請洽 TBI MOTION 業務人員。

SFK 轉造級系列規格尺寸表

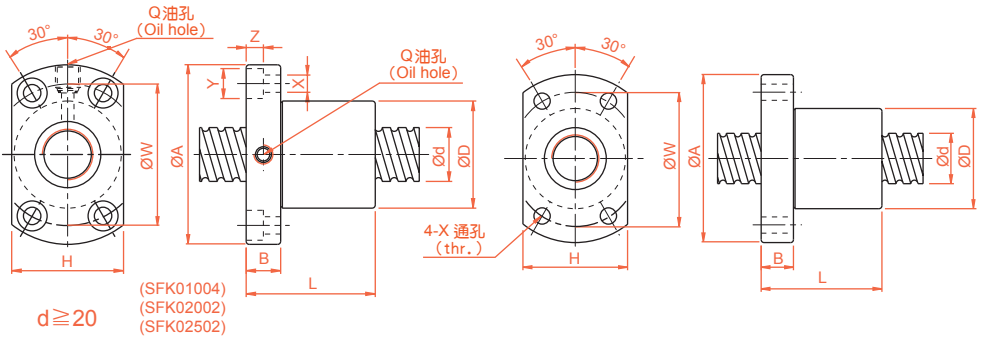

單位: mm

型號	軸徑 d	導程 l	珠徑 Da	螺帽尺寸											動額定負荷 Ca(kgf)	靜額定負荷 Coa(kgf)	剛性 kgf/ μ m
				D	A	B	L	W	H	X	Y	Z	Q	n			
SFK00601	6	1	0.8	12	24	3.5	15	18	16	3.4	-	-	-	1x3	111	224	9
SFK00801	8	1	0.8	14	27	4	16	21	18	3.4	-	-	-	1x4	161	403	14
SFK00802		2	1.2	14	27	4	16	21	18	3.4	-	-	-	1x3	222	458	13
SFK0082.5		2.5	1.2	16	29	4	26	23	20	3.4	-	-	-	1x3	221	457	13
SFK01002	10	2	1.2	18	35	5	28	27	22	4.5	-	-	-	1x3	243	569	15
SFK01004		4	2	26	46	10	34	36	28	4.5	8	4.5	M6	1x3	468	905	17
SFK01202	12	2	1.2	20	37	5	28	29	24	4.5	-	-	-	1x4	334	906	22
SFK01402	14	2	1.2	21	40	6	23	31	26	5.5	-	-	-	1x4	354	1053	24

※K 型螺帽標準品可選擇是否附刮刷器，下單前請詢問 TBIMOTION 業務人員。

單位: mm

型號	軸徑 d	導程 l	珠徑 Da	螺帽尺寸											動額定負荷 Ca(kgf)	靜額定負荷 Coa(kgf)	剛性 kgf/ μ m
				D	A	B	L	W	H	X	Y	Z	Q	n			
XSUR01204T3D-02	12	4	2.5	24	40	6	28	32	25	3.5	-	-	-	1x3	704	1413	-
XSUR01205T3D-00		5		22	37	8	39	29	24	4.5	-	-	-	1x3	702	1409	17

※XSUR01204T3D-02 螺帽標準品無附刮刷器。

滾珠螺桿產品系列

2-4 轉造級滾珠螺桿系列

B5H 轉造級系列規格尺寸表

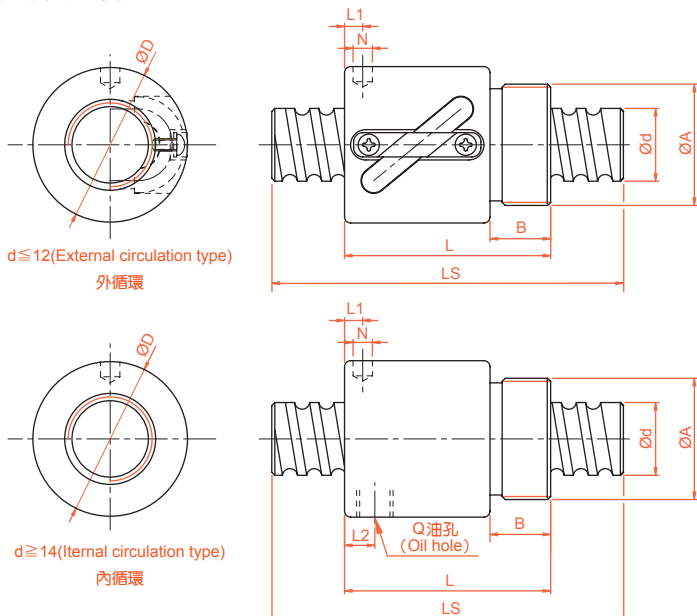

單位: mm

型號	軸徑 d	導程 l	珠徑 Da	螺帽尺寸								動額定 負荷 Ca(kgf)	靜額定 負荷 Coa(kgf)	剛性 kgf/ μm	
				D	A	B	L	L1	N	L2	Q				n
B5HR0082.5-2.5	8	2.5	1.2	17.5	M15x1P	7.5	23.5	10	3	-	-	2.5x1	189	381	11
B5HR01002-3.5	10	2	1.2	19.5	M17x1P	7.5	22	3	3.2	-	-	3.5x1	277	664	17
B5HR01004-2.5		4	2	25	M20x1P	10	34	3	3	-	-	2.5x1	400	754	14
B5HR01204-3.5	12	4	2.5	25.5	M20x1P	10	34	13	3	-	-	3.5x1	804	1649	23
B5HR01205-3.5		5	2.5	25.5	M20x1P	10	39	16.25	3	-	-	3.5x1	801	1644	24
B5HR01404-3	14	4	2.5	32.1	M25x1.5P	10	35	11	3	-	-	1x3	748	1609	26
B5HR01604-3	16	4	2.381	29	M22x1.5P	8	32	4	3.2	-	-	1x3	759	1804	24
B5HR01605-3		5	3.175	32.5	M26x1.5P	12	42	19.25	3	-	-	1x3	1077	2289	25
B5HR01610-2		10	3.175	32	M26x1.5P	12	50	3	4	3	M4	1x2	779	1601	14
B5HR02005-3	20	5	3.175	38	M35x1.5P	15	45	20.3	3	-	-	1x3	1211	2906	30
B5HR02505-4	25	5	3.175	43	M40x1.5P	19	69	32.11	3	8	M6	1x4	1724	4904	37
B5HR02510-4		10	4.762	43	M40x1.5P	19	84	8	6	8	M6	1x4	2954	7295	41

※ 外徑 Ø8~Ø16 螺帽標準品無附刮刷器。